

TP Series 51 – w/Unloader, Injector

GENERAL PUMP

A member of the Interpump Group

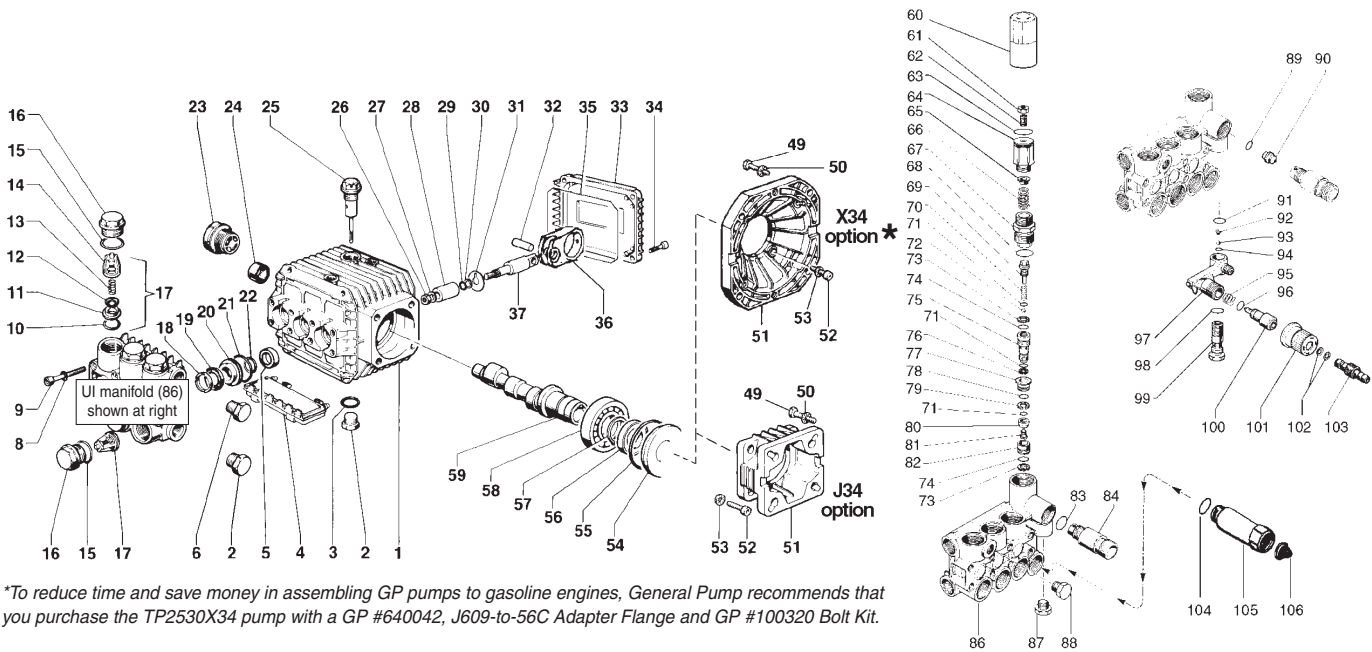

*To reduce time and save money in assembling GP pumps to gasoline engines, General Pump recommends that you purchase the TP2530X34 pump with a GP #640042, J609-to-56C Adapter Flange and GP #100320 Bolt Kit.

PARTS LIST

ITEM	PART NO.	DESCRIPTION	KIT NO.	QTY.	ITEM	PART NO.	DESCRIPTION	KIT NO.	QTY.	ITEM	PART NO.	DESCRIPTION	KIT NO.	QTY.
1.	51.0106.22	Crankcase		1	37.	51.0500.56	Plunger Rod		3	77.	36.3165.70	Valve Guide	102	1
2.	98.2100.00	Plug, 3/8		1	49.	99.2730.00	Screw, J34		4	78.	90.3589.00	O-Ring	102	1
3.	90.3833.00	O-Ring		1		99.3345.00	Screw, X34			79.	90.5075.00	Back-up Ring	102	1
4.	51.2091.02	Protector		1	50.	96.7014.00	Washer, J34		4	80.	36.3190.66	Valve	102	1
5.	90.1565.00	Oil Seal	83	3		96.7104.00	Washer, X34			81.	99.1509.00	Screw	102	1
6.	98.2041.00	Plug, 1/4		1	51.	10.0346.22	Flange, J34		1	82.	36.3164.66	Valve Seat	102	1
8.	96.6938.00	Washer		8		10.0344.22	Flange, X34			83.	90.3832.00	O-Ring	94	1
9.	99.1943.00	Screw		8	52.	99.1867.00	Screw		4	84.	10.0078.70	Nipple, 3/8 BSPP-M		1
10.	90.3841.00	O-Ring	123	6	53.	96.6938.00	Washer		4		10.0147.70	Nipple, M22-M		optional
11.	36.2003.66	Valve Seat	123	6	54.	50.2115.51	Spacer		1		10.0318.70	Nipple, 3/8 NPT-F		optional
12.	36.2001.76	Valve Plate	123	6	55.	90.4097.00	O-Ring		1	86.	51.1201.41	UI Manifold		1
13.	94.7376.00	Spring	123	6	56.	90.1644.00	Oil Seal		1	87.	98.2057.00	Cap		1
14.	36.2025.51	Valve Cage	123	6	57.	90.0667.00	Snap Ring		1	88.	98.2041.00	Cap		1
15.	90.3847.00	O-Ring		6	58.	20.2835.21	Bearing		1	89.	90.3822.00	O-Ring	94	1
16.	98.2216.00	Valve Cap		6	59.	51.0210.65	Crankshaft, TP2520		1	90.	10.0151.66	2 mm Nozzle		1
17.	36.7115.01	Valve Assy.	123	6		51.0211.65	Crankshaft, TP2526		1	91.	90.3582.00	O-Ring	94	1
18.	51.1000.51	Head Ring	96,97	3		51.0221.65	Crankshaft, TP2530		1	92.	94.8217.00	Spring	94	1
19.	90.2620.00	Packing	96,97	3		51.0218.65	Crankshaft, TP2533		1	93.	97.4782.00	Ball	94	1
20.	51.0800.70	Packing Retainer	86,96	3	60.	36.3187.51	Knob		1	94.	90.3572.00	O-Ring	94	1
21.	90.3604.00	O-Ring	86,96,97	3	61.	99.3068.00	Bolt, M8 x 25		1	95.	94.7383.00	Spring	94	1
22.	90.3835.00	O-Ring	86,96,97	3	62.	92.2223.00	Nut, M8		1	96.	90.3580.00	O-Ring	94	1
23.	97.5968.00	Sight Gauge		1	63.	90.3598.00	O-Ring, 20.35x1.78		1	97.	36.3181.51	Body		1
24.	20.2128.35	Needle Bearing		1	64.	36.3185.70	Pressure Regulator		1	98.	90.3585.00	O-Ring	94	1
25.	98.2103.00	Oil Dip Stick		1	65.	36.3169.70	Seat		1	99.	36.2563.70	Valve Seat		1
26.	92.2216.00	Nut		3	66.	94.7436.00	Spring, 15 x 36		1	100.	36.2564.70	Shuttle		1
27.	96.7008.00	Washer		3	67.	36.3184.70	Bushing	102	1	101.	36.2565.51	Knob		1
28.	51.0400.09	Plunger (15 mm)		3	68.	90.3847.00	O-Ring	102	1	102.	90.3570.00	O-Ring	94	2
29.	90.3572.00	O-Ring		3	69.	36.3188.70	Stopper	102	1	103.	36.2566.70	Coupling		1
30.	90.5022.00	Back Up Ring		3	70.	94.7332.00	Spring	102	1	OPTIONAL				
31.	96.7070.00	Finger Washer		3	71.	90.3575.00	O-Ring	102	3	104.	701115	O-Ring		1
32.	97.7310.00	Conn. Rod Pin		3	72.	97.4800.00	Ball	102	1	105.	680006	Fitting		1
33.	51.1600.22	Crankcase Cover		1	73.	90.5065.00	Back-up Ring	102	2	106.	700004	Filter		1
34.	99.1867.00	Screw		4	74.	90.3822.00	O-Ring	102	2	ZOFILKIT	Chem. Tube & Strainer			
35.	90.3917.00	Cover O-Ring		1	75.	36.3189.70	Piston	102	1					
36.	51.0301.22	Connecting Rod		3	76.	90.5025.00	Back-up Ring	102	1					

REPAIR KITS

KIT NO.	83	86	94	96	97	102	123
ITEM NO.s INCLUDED IN KIT	5	20, 21, 22	83, 89, 91, 92, 93, 94, 95, 96, 98, 102	18, 19, 20, 21, 22	18, 19, 21, 22	67, 68, 69, 70, 71, 72, 73, 74, 75, 76, 77, 78, 79, 80, 81, 82	10, 11, 12, 13, 14, (17)
NUMBER OF ASSEMBLIES IN KIT	3	3	—	1	3	—	6
NUMBER OF CYLINDERS KIT WILL SERVICE	3	3	—	1	3	—	3

TORQUE SPECS*

Position	Ft.-lbs.
2	29.4
6	14.7
9	8.8
16	60.0
23	13.2
26	11.0
34	7.3
49	14.7
52	7.3

*Decrease torque by 20% if threads are lubricated.